



- **Casambi LED-/Retrofit-Dimmer**
- R,L,C including LED Retrofit
- AdaptiveDIM (*)
- Load number indicator
- Control with Casambi and push-button
- Soft-Off, Fadetime
- Rich diagnostic tools

Functions

Digital leading edge and trailing edge phase dimmer with automatic load detection for a single dimmed phase for a max. load of 380VA. Enabled with one programmable input, local control is so much easier.

Casambi wireless operation

Casambi App automatically identifies the device and can be integrated into existing networks. All functions triggered by the buttons are individually configurable.

AdaptiveDIM (*)

The device has been specially developed to meet the modern requirements of LED lighting. Commissioning is very easy: Connect the target load, switch on, ready.

The AdaptiveDIM process automatically determines the stable lowest brightness and the ideal characteristic curve during the initial setup. There is no need to worry about dimming procedures or technical parameters.

Installation

Installation housings for dry interiors for installation or mounting in walls, ceilings or other cavities.

Due to the compact dimensions and the rounded shape, an easy installation is possible for all feed-through openings from 68 mm pitch circle.

The strain relief and terminal cover saves the need of junction boxes or other enclosures.



Easy commissioning and control
by Casambi App

CRD200 INS / CRD400 INS

Item number: 10.272 (CRD200 INS); 10.273 (CRD400 INS)



Specification		CRD200 INS	CRD400 INS
Item number		10.272	10.273
Power supply		220 ... 240V AC 50/60Hz	
Max. output power		3 ... 200 VA	3 ... 380 VA
Power consumption	watts (on idle, switching)	0,6W / 1,8W at full load	
Terminals and wiring	Screw terminal wiring	single-wire: 0,2 ... 4 mm ² fine-wire: 0,2 ... 2,5 mm ² 6 mm (+/- 0,5 mm) max. 0,2 Nm	
	Striping length		
	Tightening torque		
Operation- and indication units		Device Button, Status-LED	
Protection circuits		Short circuit with auto restart, over temperature (derating), over current, over Voltage	
Environment	Type of protection housing	IP20, Class II	
	Temperature ambient (ta)	0° ... +50° Celsius	0° ... +28° Celsius
	Temperature critical (tc)	70° Celsius	
	Humidity	5 - 80% non-condensing	
Casambi	Bluetooth Low Energy (BLE)	App available for Android and iOS	
Alternate control		Casambi enabled push-button input (230V AC)	
Approbation		CE	
Design	Construction	Installation housing Licensed under DM/053379 of Tridonic	
	Mounting	Installation in ceiling, wall or luminaire	
Dimensions	(Height x width x depth) mm	29,5 x 51x 101,5 mm	
	Weight	75g	100g
Customs	HS-Code/ TARIC-Number	85365080	
Co-applicable documents		Installation instructions; manual	

Important: Notice all safety instructions and related documents for Installation and operation. Names, trademarks, products or companies can be claimed. All rights are on their respective owners.

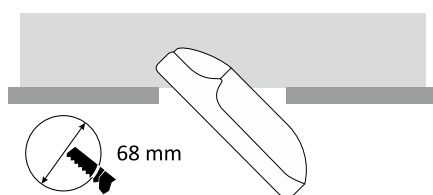
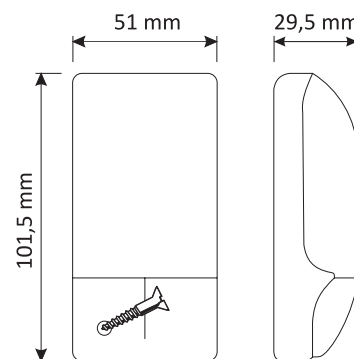
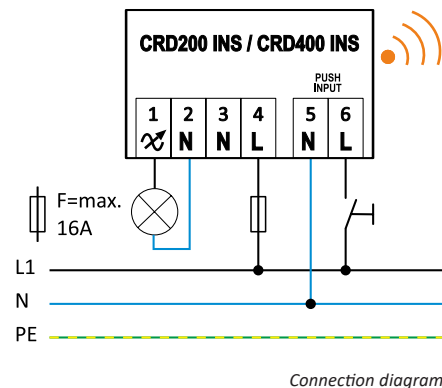

Ceiling installations

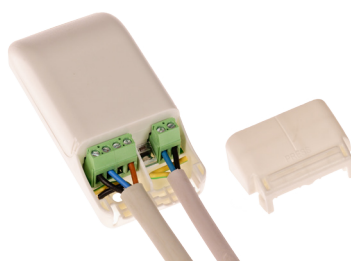

Wiring with strain relief

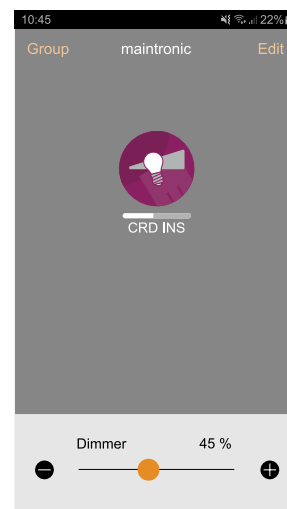

Screenshot App